



Model No.

X0801512Y 80x80x15mm

Frame and Impeller Material :
Plastic (UL 94V-O)

Bearing system :
Ball Bearing (B)
Sleeve Bearing (S)

Lead Wires :
UL 1007 AWG 28 or equivalent.
Red:+, Black:-

Model No. :
X0801512Y

X=Bearing system, can be B or S type..
Y=Fan speed, can be L, M, H or HH.

Net Weight :
55g

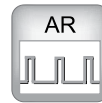

OUTLINE

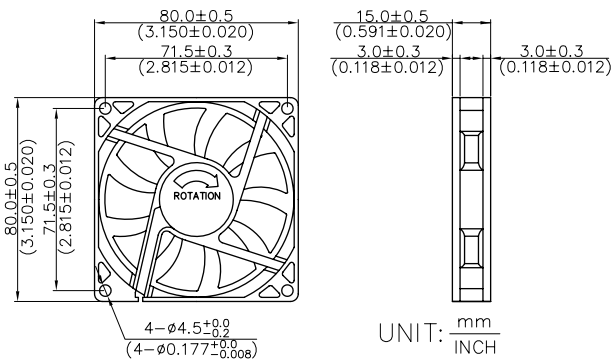

CHARACTERISTIC CURVES

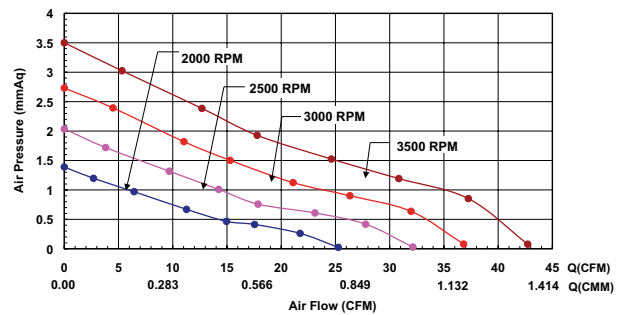

SPECIFICATIONS

Item	Operating Voltage Range	Rated Voltage	Rated Current	Rated Input Power	Speed	Max Air Flow		Max Air Pressure		Noise
	V _{DC}	V	Amp	Watt	R.P.M	m ³ /min	CFM	mmH ₂ O	inH ₂ O	dBA
B/S0801512L	6~13.8	12	0.11	1.32	2000	0.72	25.26	1.39	0.05	20.4
B/S0801512M	6~13.8	12	0.13	1.56	2500	0.91	32.14	2.04	0.08	25.5
B/S0801512H	6~13.8	12	0.19	2.28	3000	1.04	36.81	2.73	0.11	30.3
B/S0801512HH	6~13.8	12	0.35	4.20	3500	1.21	42.73	3.50	0.14	34.1